Actel Silicon Sculptor II

Windows[®] Environments User's Guide

This manual is intended for Silicon Sculptor II series programmers, and may be used for Silicon Sculptor I series programmers with restrictions as mentioned in the text, provided no more than two Silicon Sculptor II series programmers are chained together for concurrent programming. This restriction does not apply to Silicon Sculptor I series programmers.



Actel Corporation, Mountain View, CA 94043

© 2004 Actel Corporation. All rights reserved.

Printed in the United States of America

Part Number: 5029111-1

Release: March 2004

No part of this document may be copied or reproduced in any form or by any means without prior written consent of Actel.

Actel makes no warranties with respect to this documentation and disclaims any implied warranties of merchantability or fitness for a particular purpose. Information in this document is subject to change without notice. Actel assumes no responsibility for any errors that may appear in this document.

This document contains confidential proprietary information that is not to be disclosed to any unauthorized person without prior written consent of Actel Corporation.

Trademarks

Actel and the Actel logo are registered trademarks of Actel Corporation.

Adobe and Acrobat Reader are registered trademarks of Adobe Systems, Inc.

All other products or brand names mentioned are trademarks or registered trademarks of their respective holders.

SILICON SCULPTOR II LIMITED WARRANTY

The Silicon Sculptor II is manufactured by BP Microsystems, Inc. for Actel Corporation under an OEM agreement. There are two versions of the Silicon Sculptor; a single-site version, which will be referred to as the Silicon Sculptor II. Actel Corporation warrants the single-site Silicon Sculptor II product against defects in material or workmanship for a period of one year as follows:

For a period of three years for the now obsolete Silicon Sculptor I and one year for the current Silicon Sculptor II from date of purchase, Actel Corporation, through BP Microsystems, Inc., will repair or replace any defective product at no charge. Whether the warranted product should be repaired or replaced is wholly within the discretion of Actel Corporation and BP Microsystems, Inc.

This warranty does not cover any damage due to accident, misuse, abuse or negligence, nor does it cover normal wear items such as socket modules and filters.

You should retain your dated bill of sale as evidence of the date of purchase.

REPAIR OR REPLACEMENT AS PROVIDED UNDER THIS WARRANTY IS THE EXCLUSIVE REMEDY OF THE PURCHASER. IN NO EVENT SHALL ACTEL CORPORATION OR BP MICROSYSTEMS, INC. BE LIABLE FOR ANY SPECIAL, INCIDENTAL OR CONSEQUENTIAL DAMAGES, NOR FOR ANY DAMAGES RESULTING FROM USE, MISUSE OR MODIFICATION OF THIS PRODUCT. EXCEPT TO THE EXTENT PROHIBITED BY APPLICABLE LAW, ANY IMPLIED WARRANTY OR MERCHANTABILITY OR FITNESS FOR A PARTICULAR PURPOSE IS SPECIFICALLY DISCLAIMED. UNDER NO CIRCUMSTANCES SHALL TOTAL LIABILITY for ACTEL CORPORATION OR BP MICROSYSTEMS, INC. EXCEED THE PURCHASE PRICE OF THE PRODUCT.

This warranty gives you specific legal rights, and you may also have other rights that vary from state to state.



Table of Contents

Introduction	7
Document Organization	7
Document Assumptions	7
Document Conventions	7
Actel Manuals	8
Online Help	9
1 Getting Started	11
Compatibility	11
Hardware Installation	11
Software Installation	12
2 Command Reference	19
Pull-Down Menus	19
Action Buttons	24
Main Screen File Tabs	31
Keyboard Usage and Hot-Keys	36
3 Troubleshooting	39
Tech Support Program	39
Software Updates	41
FAQs	42
Errors While Programming	43
Cleaning a Dirty DIP Socket	43
Error Messages and Suggested Actions	44
A Product Support	51
Customer Service	51
Actel Customer Technical Support Center	51
Actel Technical Support	51
Website	51
Contacting the Customer Technical Support Center	52
B Glossary	53

Table of Contents

Introduction

Thank you for selecting the Silicon Sculptor Programming System. This user's guide is designed to help you take full advantage of the Silicon Sculptor's capabilities. The bulk of this manual is intended for Silicon Sculptor II series programmers, but may be used for Silicon Sculptor I series programmers and Silicon Sculptor 6X programmers, as the software is identical. The main practical restriction is that no more than two Silicon Sculptor II series programmers can be chained together for concurrent programming, and a standard IEEE 1284 parallel cable (EPP) must be used for this purpose. The optional multi-headed extender cable can only be used on Silicon Sculptor I series programmers; it is not to be used on Silicon Sculptor II series programmers.

Document Organization

The *Silicon Sculptor II User's Guide* is divided into the following chapters:

Chapter 1 - Getting Started is a quick reference for beginning use of a programmer through the ActelWin software.

Chapter 2 - Command Reference is organized by function and command, listing details and usage.

Chapter 3 - Troubleshooting covers error messages that are not self-explanatory and helps you identify problems.

Appendix A - Product Support provides information about contacting Actel for customer technical support.

Appendix B - Glossary defines some useful terms that appear in this manual.

Document Assumptions

The information in this guide is based on the following assumptions:

1. You are familiar with PCs and are running Windows 95/98/2000, Windows XP, or Windows NT 4.0 or later.
2. You are familiar with Actel FPGA architecture and Actel FPGA design software.

Document Conventions

This manual uses the following conventions:

Information input by the user follows this format:

keyboard input

The contents of a file follows this format:

```
file contents
```

Messages displayed on the screen appear as follows:

```
screen message
```

Actel Manuals

Actel's Designer Series software includes printed and online manuals. The online manuals are in PDF format on the Designer CD-ROM and the Libero CD-ROM in the “\Designer\docs” folder in the Designer and the Libero software directory. These manuals are also installed onto your a system when you install the Designer software. To view the online manuals, you must install Adobe Acrobat Reader from the CD-ROM. For the most up-to-date documentation, go to the [Actel website \(www.actel.com\)](http://www.actel.com).

Online Help

The Designer Series software comes with online help. Online help specific to each software tool is available in Designer, ACTgen, Silicon Explorer, and Silicon Sculptor. Online help is also available within the Libero IDE software and Synplicity Synplify® software.

Getting Started

This chapter describes how to install and test the software. It also contains important operating information that is useful when programming chips. For more detailed information about each command listed in this chapter, see “[Command Reference](#)” on page 27.

Compatibility

Silicon Sculptor II is designed to operate with any PC with the following minimum system requirements:

- Windows NT 4.0 with SP5 or SP6
- Windows 2000 with SP1 or SP2 or SP3 or SP4
- Windows XP with SP1
- Pentium 133 or higher (Pentium 200 or higher recommended) processor
- 64 MB of available memory for use
- 50 MB of available hard disk space · VGA or higher-resolution video adapter (SVGA 256-color and 800x600 or higher resolution recommended)
- Parallel printer port (LPT1, LPT2, or LPT3)
- CD-ROM disk drive, and a hard drive.

Note: For NT 4.0 and Windows 2000 systems, you must have administration rights to the local workstation for installation purposes. For NT 4.0, Windows 2000, and Windows XP systems, you must have administration rights to the local workstation for installation purposes.

The Silicon Sculptor II has nonvolatile memory. More specifically, it has Flash memory (29F200TB) on a board that stores the BIOS and various small EEPROMs. It also has SIMM modules that store the programming data (such as afm/bit stream). The programming data is never stored in the nonvolatile memory.

Hardware Installation

After you unpack the equipment, you are ready to connect the Silicon Sculptor II to your PC.

To connect the Silicon Sculptor II to your PC:

1. **Connect the programmer to a parallel printer port on your PC.** Connect one end of the cable to the programmer’s connector and tighten the screws. Plug the other end of the cable into your parallel printer port.

2. **Verify that you have connected to the correct parallel port on your computer.** Actel recommends that you dedicate a port to the programmer. Connecting to a serial port or third party card can damage the programmer. This type of damage is not covered by the warranty.
3. **Power up the programmer.** Plug the programmer AC power cord into a power socket.
Note: The Silicon Sculptor II power supply operates from 90 to 250 VAC for simplified worldwide use.
4. **Turn on the computer and programmer.** Both the green Power LED and the yellow Active LED on the programmer site will light up. Silicon Sculptor II is performing a Power On Self-test when the Active LED is on. After a minute or two, the yellow Active LED will turn off and only the green Power LED will remain on. If the Fail LED turns on, the Silicon Sculptor II has detected an error during the Power On Self-test. If this occurs, call Actel's technical support line. See [“Contacting the Customer Technical Support Center”](#) on page 60 for a complete list of technical support options.

Software Installation

Your software installation procedure depends on whether you downloaded the software from the internet or are installing from a CD-ROM. Follow the instructions below to install the Silicon Sculptor software on your computer.

To install the software from the Internet download:

Go to <http://www.actel.com/custsup/updates/silisculpt/> and download the latest Windows version of Sculptor programming software.

When prompted, choose the drive and directory the self-extracting .EXE file will be saved in. Once the download is complete, double-click the .EXE file to install the software.

To install the software from CD-ROM:

1. **Insert the Silicon Sculptor CD.** If the CD start-up browser screen does not start automatically when you insert the Silicon Sculptor CD, go to **Start > Run**, then type the following command in the **Open** box:

```
d: \setup.exe
```

The “d” in the above command represents the drive letter of your CD-ROM. If your CD-ROM has a different drive designation, substitute the letter that designates your CD-ROM drive.

2. **Select a location for the SculptW program files.** Once activated, the installation screen for the software opens. The installation prompts you to choose a folder name and location for the SculptW program files. The installation software provides a default location. To place these files in an alternate location, click in the field provided and type the location address.

If you have a previous version of the software installed on your computer, the installation procedure prompts you to uninstall the older version before continuing the new installation procedures.

3. **Run Silicon Sculptor.** Go to **Start > Programs > Silicon Sculptor**.

Silicon Sculptor Basics

SculptW utilizes all the standard functions of windows-based applications, including pull-down menus, action buttons, and hot keys, along with online help files. See [“Command Reference” on page 27](#) for more information on these functions.

The initial screen of the SculptW software divides into two sections. The uppermost section is the main program window. It contains the software title and version number, as well as the pull-down menus and the tracking system for the devices you are about to program (Figure 1-1).

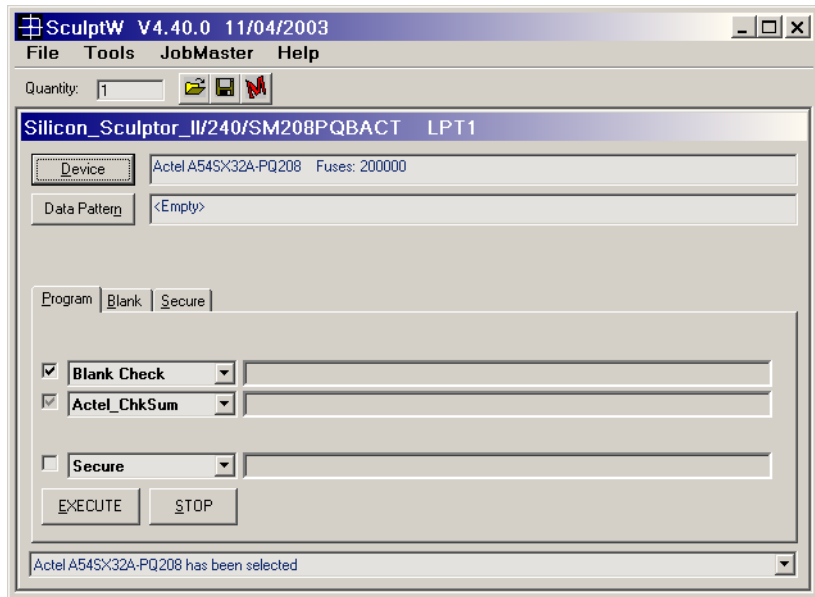

Figure 1-1. SculptW Main Screen

Use the secondary, floating window (known as the Action/Function window) to designate devices and data patterns and start and stop programming actions (see “[Command Reference](#)” on page 27 for a more information on these functions). The title bar of the Action/Function window displays the following information:

- **Programmer detected or selected.** In the example shown in [Figure 1-2](#) on page 13, the selected programmer is **Silicon Sculptor II**.
- **The technology adapter and socket module detected by SculptW.** In the example shown in [Figure 1-2](#) on page 13, the technology adapter and socket module is **SM208PQBACT**.
- **The location of the parallel port that detects the programmer.** In the example shown in [Figure 1-2](#) on page 13, the parallel port is **LPT1**.

Note: If the software does not detect a programmer, it automatically starts in DEMO mode, and

all actions/functions are available in the DEMO mode except programming a device. You can add a programmer after startup in DEMO mode by going to **File > Configure**.

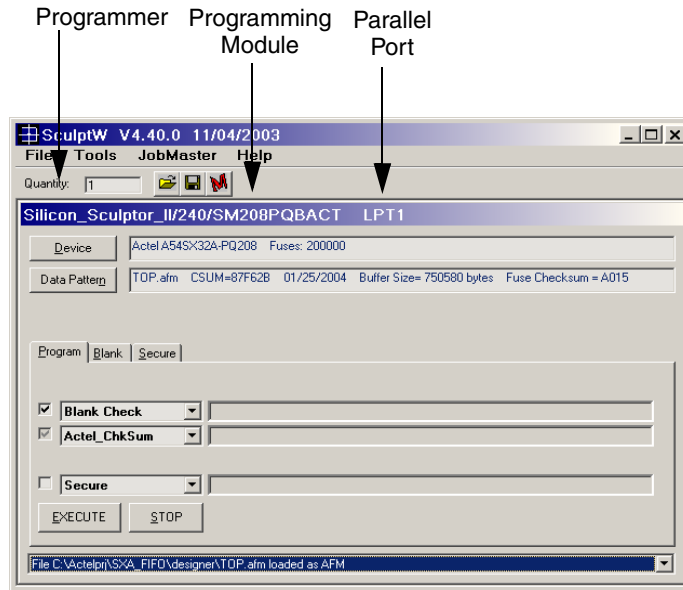

Figure 1-2. SculptW Detects Silicon Sculptor

The bottom pull-down menu, visible only when the program window is fully expanded, keeps a running list of all the actions you performed and the device(s) you select during active use of the software. Once you exit the software, the tracking list is reset.

Selecting a Chip

Click the **Device** button in the **Action/Function** window to select a chip. The **Device** button opens the **Select Device** dialog box. The list of parts in the **Select Device** dialog box contains every device

currently supported by Silicon Sculptor II (Figure 1-3). Choose a device by scrolling down the available list, or use the search engine by typing directly into the **Look for** text field.

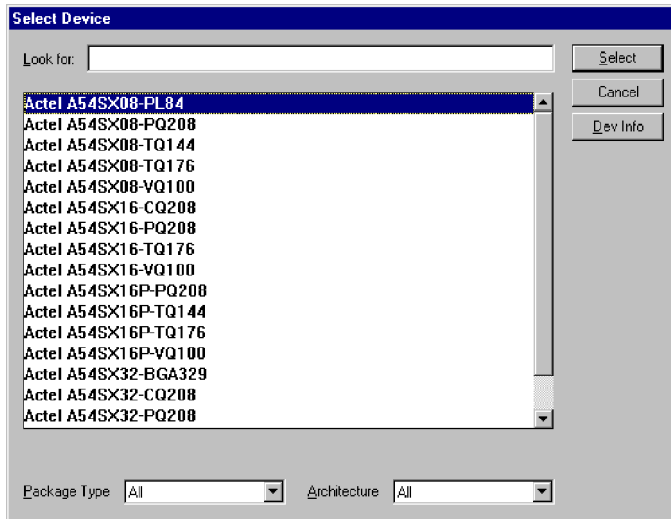

Figure 1-3. Select Device Window

The search engine associates characters typed in the **Look for** field with the characters that are found in one or more string items listed in the software's device inventory. These characters do not have to be the beginning of the string line (i.e. the manufacturer's name).

If you type the letters “s” and “x,” the software narrows the list down to any parts listed with those two letters in that particular order, shortest name first. As you type, the list becomes more refined until you select a particular device. See Figure 1-4.

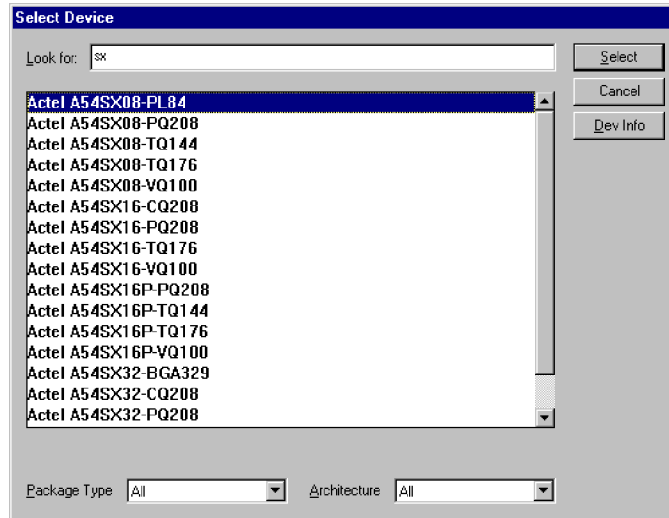

Figure 1-4. SculptW Search Engine

To narrow your choices before you search, select a Package Type and/or Architecture from the pull-down menus. Any package type or architecture not matching the type selected in the pull-down menu is excluded from the search. See “[Command Reference](#)” on page 27 for more information on the device selector.

Loading a Data Pattern Programming File

To load a data pattern programming file:

(The AFM file format is for Antifuse Families and the STAPL/BIT file formats are for Flash Families)

1. **Open the Data Pattern window.** Click the **Data Pattern** button in the **Action/Function** window. See [Figure 1-5](#).

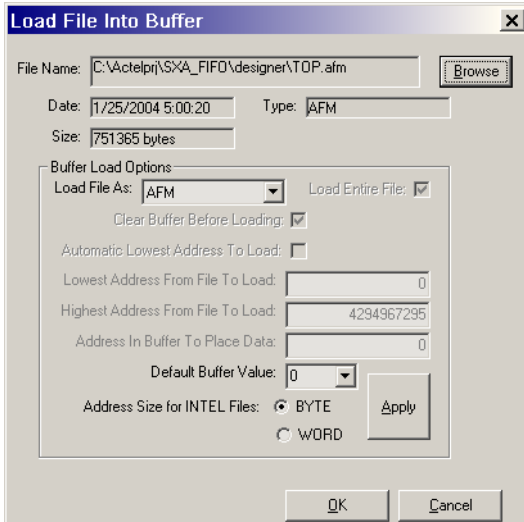

Figure 1-5. Data Pattern Dialog Box

2. **Load File into Buffer.** Click the **Open** button and click the **Browse** button and select a programming file. Confirm the file information and click **OK** to continue. See Figure 1-6.

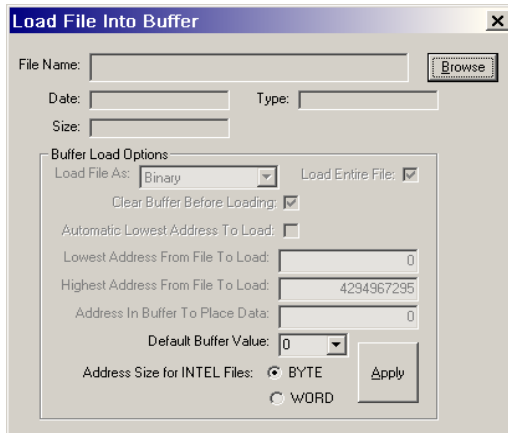

Figure 1-6. Load File Into Buffer Dialog Box

The software automatically identifies the file type and displays the information in a the Buffer Load Option section of the dialog box for verification. See Figure 1-7. Once you confirm the file information, click **OK**. The file will load into the data buffer. (A confirmation window will be displayed to prompt to clear buffers. Click **OK** to clear buffer).

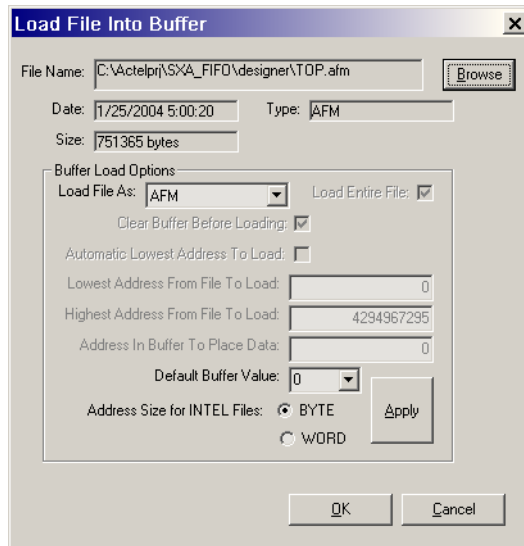

Figure 1-7. Load File Into Buffer Dialog Box

After the file is loaded, click the **Cancel** button to exit.

Data Pattern Information

This section provides a description of the displayed information for the data pattern.

Antifuse Devices

When you load the buffer, information regarding the loaded AFM file is displayed next to the Data Pattern Button as shown in Figure 1-8.

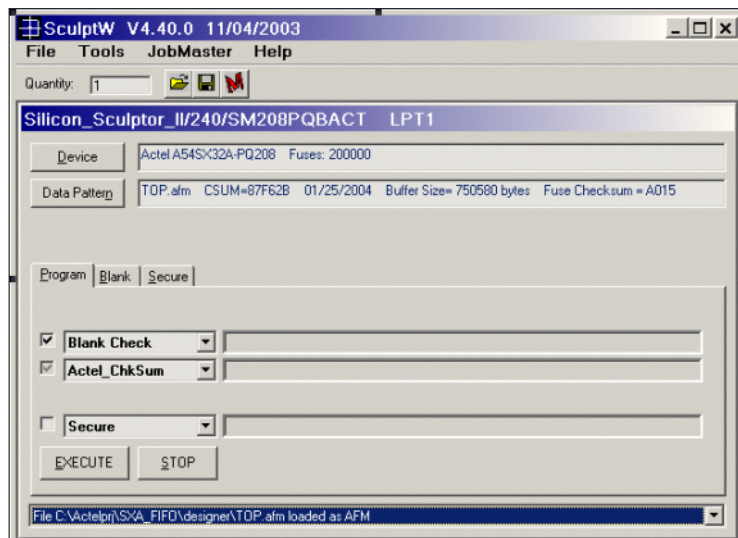

Figure 1-8. AFM File Information in the Data Pattern

Fuse Checksum (Four Digit HEX Number)

This is read directly off from the fuse checksum line in the AFM file:

```
|VAR FUSCHECKSUM XXXX
```

Note: XXXX is a 4 digit HEX number.

Changing this manually will have no effect on the other two checksums, but problems will occur when you try to verify the part later after programming.

The fuse checksum is programmed into all Actel antifuse devices at the end of the programming sequence. This information can be used to match a programmed device to its programming (AFM) file. The fuse checksum is calculated from the fuses in the AFM

file. This number will be unique for each fuse map. This number can also change if the target die is changed, even though no change has been made to the layout of the device.

Note: You must not modify any contents of the AFM file to avoid the integrity and contents of the AFM file from corruption.

File CHECKSUM (Eight Digit HEX Number)

In the AFM file, there is also a commented line in the header, which is the File Checksum of the AFM file:

```
CHECKSUM XXXXXXXX
```

Note: XXXXXXXX is a 8 digit HEX number.

During loading, the software looks at the contents of the file that are not commented, computes a file checksum, and compares it to this. If this does not match, an error will occur as shown below:

```
checksum comparison failed...read checksum is 416EC623...computed checksum is 4a56a41f.
```

CSUM

CSUM is calculated with a combination of the device you select and the data in the buffer (which contains the programming file contents). A different CSUM number means a different setup is configured, which is a combination of device you select and the programming file. To verify programming the data programmed to the device with the programming file, use the Fuse Checksum value.

Placing a Chip in the Socket

Refer to the appropriate device programmer manual to place a device in the socket module.

Note: Parts must not be inserted or removed when the ACTIVE LED is on.

Programming a Device

After you select a target device and load a data pattern (programming file), you can program the device by selecting the appropriate actions in the tab windows. See Table 1-1 for action tab descriptions.

Table 1-1. Action Descriptions

Action Tab	Description
Program	The Program tab executes all actions including Blank Check, Program, and Secure in one step. You can also do the Actel Checksum action in this tab.
Blank	The Blank tab performs the Blank Check action to check the state of the device.
Secure	The Secure tab performs the Secure action to program only the security fuse of the device.

You can perform the Blank and Secure actions individually or you can perform these actions during the programming sequence.

Blank Check Action

You can perform the Blank Check action to check the state of the device.

To perform the Blank Check action:

1. Select the Blank tab.
2. Click Execute.

Secure Action

You can perform the Secure action to program only the security fuse of the device after you have previously programmed a device.

To perform the Secure action:

1. Select the Secure tab.
2. Click Execute

Program Action

Follow the steps below to program a device.

To program a device:

1. Select Program from the tab window.
2. Check the “Blank Check Action” checkbox in the Program tab (Recommended).
3. Select Program from the second pull down menu. See Figure 1-9.
4. If desired, check the “Secure Action” textbox in the Program tab to program the security fuse.
5. Click Execute.

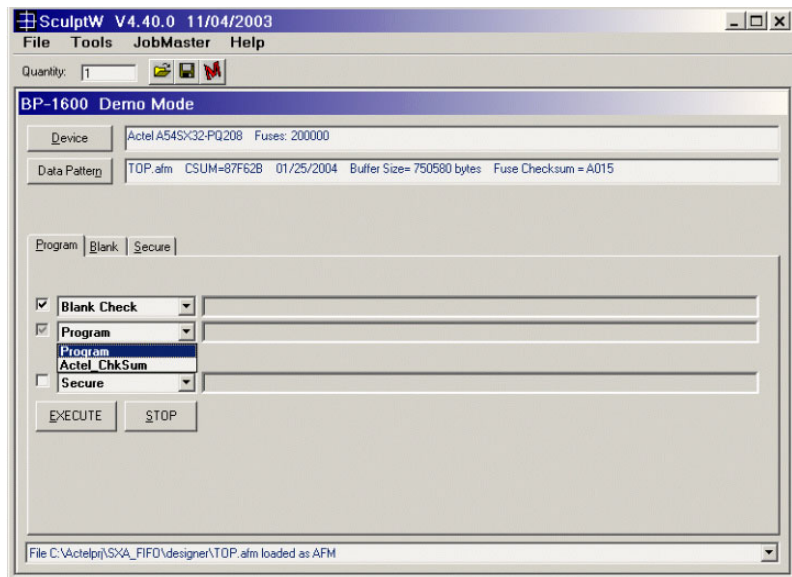

Figure 1-9. Programming Dialog Box

After you programmed the device, verify that the device is programmed successfully by performing the Actel Checksum action.

To perform the Checksum action:

1. Uncheck the Blank Check option in the Program tab if checked.
2. Select Actel_ChkSum in the second pull-down menu (see Figure 1-9).

3. Uncheck the Secure option if checked.
4. Click Execute.

Note: The software displays a message in the log window with the correct fuse checksum that matches the AFM file's FUSCHECKSUM.

Concurrent Programming

Silicon Sculptor II is a concurrent programmer, multiple sites can simultaneously program the same design. Your PC is used to hold the data that will be programmed into the devices. Specific programming algorithms and instructions are stored on the PC and downloaded to the programmer when you select a chip and load the buffer. Thus, the algorithm is actually executed by each programmer's internal microprocessor. This guarantees accurate wave forms and precisely controlled critical time delays, independent of the PC's performance. The speed of your PC will only affect the rate at which the programming algorithm and data is downloaded to the programmer and will not affect programming yield.

Two is the maximum number of Silicon Sculptor II units that you can connect for concurrent programming. The two Silicon Sculptor IIs must be joined together via a standard IEEE 1284 parallel cable (The special extension cable for use with the Silicon Sculptor I's may not be used with Silicon Sculptor II's).

The Individual System Diagnostic Self-Test section explains how to setup two Silicon Sculptor IIs to facilitate concurrent programming.

Note: This section assumes that you have installed the Sculptor programming software. If you have not installed it, download the latest version from the Actel Website.

Individual System Diagnostic Self-Test

Before attempting concurrent setup, you should connect each Silicon Sculptor II individually and run them through a full system diagnostic self-test. One parameter to pay special attention to is the BIOS version number. Sculptors will only operate concurrently if the BIOS version is the same on each one. You can find the BIOS version number in the Diagnostic test result summary, as shown in Figure 1-10.

```

BP Diagnostics Output
Port: 1
Serial Number: 28610
Pin drivers: 240
BIOS: V2.12 in RAM (V1.18 in ROM)
Speed: 96.0MHz
RAM: 18432KB
Free Mem Addr: 00090000
Analog: 48
Digital: 192
Misc: 0036 194 11990 31 608 2496 16666
SWSupport Date: No expiration date
Model: Silicon_Sculptor_II/240
Tech. Adapter: TA_VLV_ACT
Socket Module: SM208PQBACT
Package Type: QFP
Package size: 50...208
Parallel Port: (EPP)
Port: 1
Unit Number: 1
Serial Number: 28610
Pin drivers: 240
BIOS: V2.12 in RAM (V1.18 in ROM)
Speed: 96.0MHz
RAM: 18432KB
Free Mem Addr: 00090000
Analog: 48
Digital: 192
Misc: 0036 194 11990 31 608 2496 16666
SWSupport Date: No expiration date
Model: Silicon_Sculptor_II/240
Tech. Adapter: TA_VLV_ACT
Socket Module: SM208PQBACT
Package Type: QFP
Package size: 50...208
Parallel Port: (EPP)
Serial Number: 28610, 03/12/04 18:03:37
Unit Number: 1
CPU/RAM/ROM/LOGIC PASSED
COMMUNICATIONS PASSED
POWER SUPPLIES PASSED
MOTHERBOARD ANALOG PASSED
PIN DRIVER BOARDS PASSED
TECHNOLOGY ADAPTER PASSED
Testing Socket Module (SM208PQBACT). OK
SOCKET MODULE PASSED
FINE CURRENT PASSED
INDEPENDENCE PASSED
CURRENT REGULATORS PASSED
MOTHERBOARD PASSED
=====
SYSTEM SELF TEST PASSED

```

Figure 1-10. Diagnostic Test Result Summary

Please refer to section “Testing the Hardware” on page 47 for diagnostic test procedures.

Concurrent Setup

The concurrent setup is very straight forward, follow the instructions below.

To perform concurrent setup:

1. Make sure the Sculptors are powered OFF.
2. Connect power cords to each Sculptor and plug them in.
3. Connect the first Sculptor to the parallel port of the PC.
Note: Do not use any print buffers or electronic switches on the same port as the programmer.
4. Connect the second Sculptor to the first Sculptor in a daisy chain configuration using the custom expansion cable as shown in Figure 1-11.

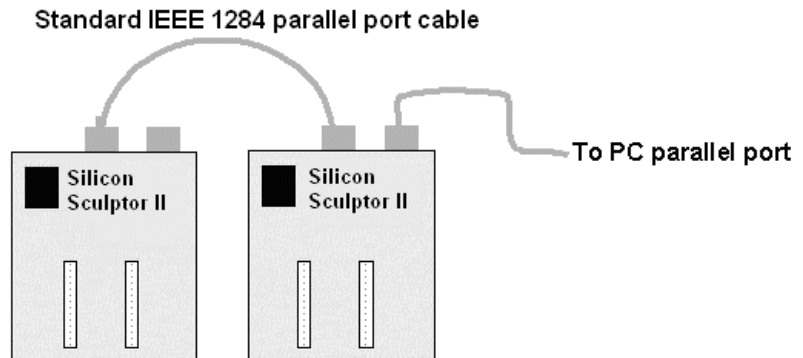

Figure 1-11. Concurrent Setup

5. Power on both Sculptors.
6. Invoke the Sculptor Windows software.
7. Once communication has been established, perform a system Diagnostic self-test.

This system self-test looks very similar to the individual self-test, except that two units are detected. This is apparent in the second screen of the self-test as shown in Figure 1-12 below.

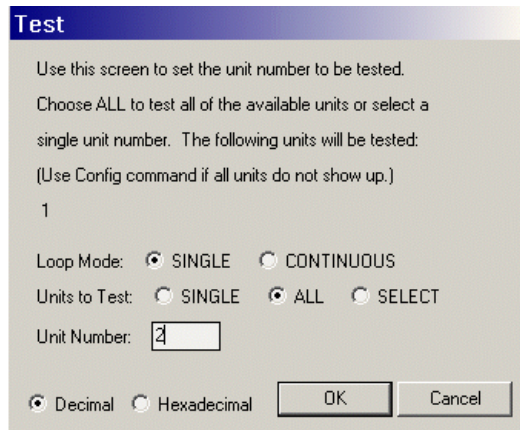

Figure 1-12. Screen of Self-Test Dialog Box

Executing Concurrent Operation

Once all systems have passed the self-test, you are ready to insert the correct adaptor modules and begin programming devices. Follow the same procedures as described in “Programming a Device” on page 20.

For Silicon Sculptor I concurrent programming, please refer to the following document: <http://www.actel.com/apps/guru/sep98/hw1675.html>.

Command Reference

The Actel Silicon Sculptor software places standard, device-specific functions at your command. Commands are located in drop down menus and file tabs in the main screen as well as hot-link buttons on each active dialog box. To execute a command, select the appropriate button or option.

Pull-Down Menus

The following section describes the pull-down menus available in Actel Silicon Sculptor software.

File

Use the commands under the **File** menu to control the communication with the programmer, input special code to enable advanced features, and monitor the number of copies you want to make. In addition, use the commands under the File menu to reset the program settings to their defaults and modify certain global options.

Configure

Configure re-establishes communication with the programmer. This allows you to change programmers if necessary. It also opens a dialog box that lists several options. This dialog box enables you to switch the handler type from manual to auto-handler status, and to specify an experience level (**Novice** or **Experienced**).

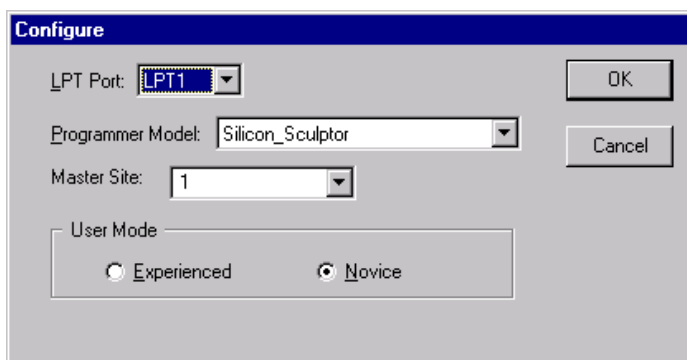

Figure 2-1. Configure Dialog Box for Actel Silicon Sculptor

The following menus are available in the Command dialog box in Silicon Sculptor:

- **LPT Port** identifies which parallel port is connected to the programmer. Choose from **DEMO**, **LPT1**, **LPT2**, or **LPT3**. Selecting **DEMO** disables communications with the programmer. You

can utilize any of the software's functions while in DEMO mode, but you cannot program a device.

Note: DEMO is the default selection if Sculptor cannot detect a programmer.

- **Programmer Model** identifies which model programmer you are using. Select any programmer in DEMO mode and view the list of devices supported on that particular model in the Device Select dialog box.
- **Master Site** indicates the Silicon Sculptor programmer that is connected to the PC.
- **User Mode** distinguishes between Experienced and Novice modes. Experienced mode permits options not allowed in Novice mode. For example, clearing the buffer and displaying ICC measurements on Verify and Test is available only in Experienced mode.

Selecting **Novice** instructs the program to prompt you to accept or cancel before you perform each operation. Novice is the default setting.

Upgrade

The **Upgrade** dialog box (Figure 2-2) allows you to input a special code, which enables Advanced Features (AFS) in the software. This code is required in order to enable the Actel Silicon Sculptor program to continue communications with the device programmer and to get support for all Actel devices. For more information, see “[Troubleshooting](#)” on page 47.

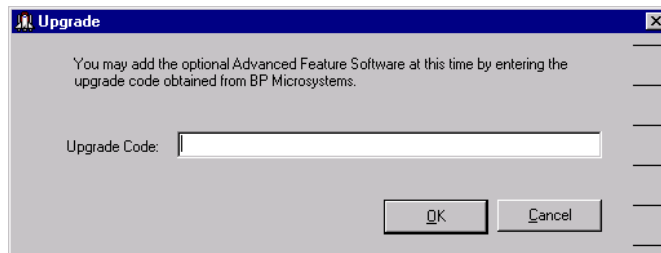

Figure 2-2. Upgrade Dialog Box

To receive an upgrade code, contact Actel Technical Support. See “[Product Support](#)” on page 59 for a complete list of technical support contact information.

Tools

Use the commands in the **Tools** menu to reset the Silicon Sculptor configuration.

Programmer Diagnostic

Programmer Diagnostic runs the programmer diagnostic test, also called self test (Figure 2-3). The Silicon Sculptor diagnostics ensure that the power supplies function properly and test the integrity of all the pin drivers. Select **Actel Diagnostic** from the **Device** tab.

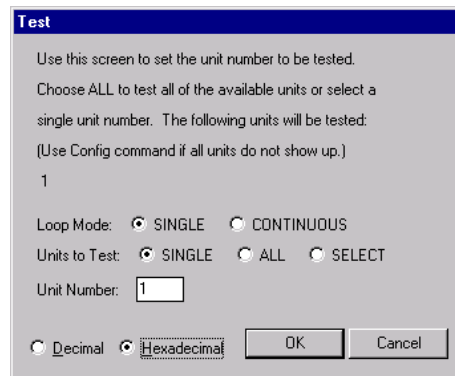

Figure 2-3. Diagnostics Dialog Box

Click OK to run the test on the CPU, RAM, ROM, logic communication, power supplies, motherboard analog, pin driver boards, current regulators, and mother board. The **Diagnostics Report** dialog box (Figure 2-4) opens when the tests are complete.

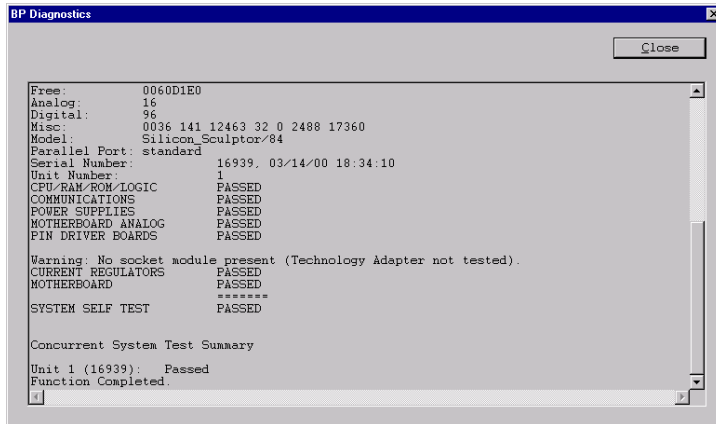

Figure 2-4. Diagnostics Report Dialog Box

Default Configure

Default Configure (Figure 2-5 on page 31) enables you to reset all the settings to the default configuration. When this option is selected, you are asked to confirm whether or not you want to reset to the default configuration. This option is available to allow you to reset any given command back to its original settings whether or not you have changed the command.

For example, if a device calls for a mandatory verify and the operator changes it to Verify Twice, the Default Configure option will allow the user to change the setting back to a single verify.

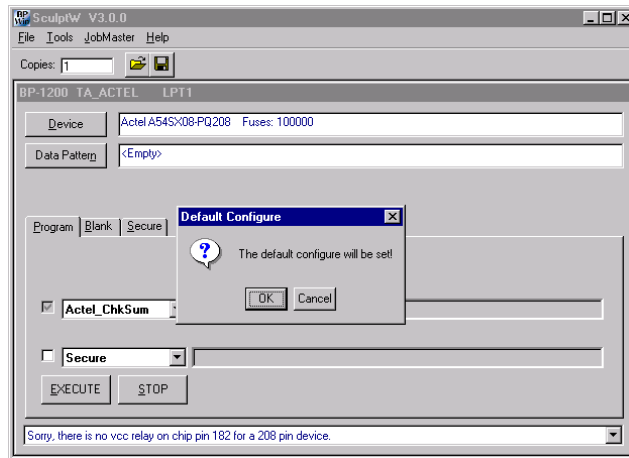

Figure 2-5. Default Configure Dialog Box

Options

The Options dialog box enables you to set global options.



Figure 2-6. User Options Dialog Box

- **Error Beep** turns on or off the sounds used to indicate completion, errors, end of job, etc.
- **Elapsed Time** displays the duration of time of a specific operation, i.e. Read, Program, etc.

Copies

The Copies field enables you to enter the number of devices you want to program. The software automatically tracks how many you have finished, how many failed, and how many remain to be programmed. When Sculptor reaches the Copies Number successfully, it displays a Job Summary report for printing.

Help

Help/Tech Support lists the phone numbers and e-mail address for reaching Actel Technical Support. You can also refer to “[Product Support](#)” on page 59 for technical support contact information.

Help/About Actel Silicon Sculptor displays the current Silicon Sculptor version number and software specifics.

Action Buttons

Actel Silicon Sculptor includes action button links (commonly known as “buttons”) as well as pull-down menus and file tabs that enable you to direct the program to specific locations and tasks. The following is a list of the action buttons and their functions.

Device Button

The **Device** button enables you to access to the list of devices supported by the designated device programmer via the Select Device dialog box.

Select Device Dialog Box

The **Select Device** dialog box ([Figure 2-7](#)) offers a list of devices supported on the programmer model selected in **Configure** or detected by the software. Select a device to configure the

programmer with the correct programming algorithm. The algorithm is specified by Actel and contains the voltage, timing, and pin-out requirements.

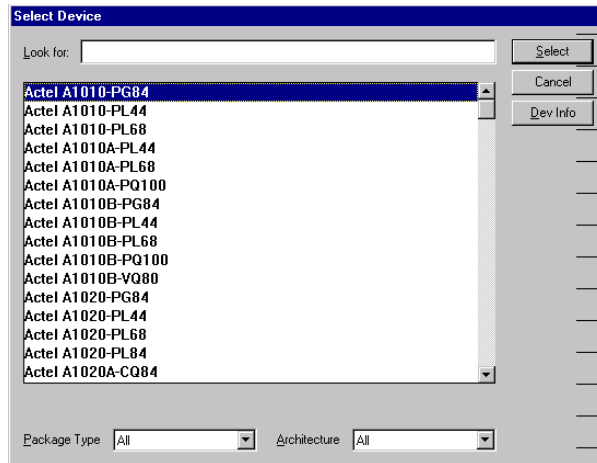

Figure 2-7. Select Device Dialog Box

Type the part number in the **Look for** text box. Notice that as you type the characters the device list narrows to show only those devices containing the characters you have typed, in the order you type them. To further narrow the list, designate a particular package type or architecture.

Click the desired selection from the list of supported devices. It is important to select the correct device for programming. Some character suffixes at the end of the part number pertain to temperature or speed ratings and are not of importance for programming. Choose the device that most closely matches your device part number.

When you have highlighted the correct device and entered the appropriate information, click the **Select** button to load the algorithm for that device or **Cancel** to escape without selecting.

The **Package Type** dialog box narrows the search by listing only devices with the package type you select.

The **Architecture** dialog box narrows the search by listing only devices with the type of architecture you select.

Note: Changing the **Package Type** and **Architecture** fields can cause the changed options to revert to the default settings.

Dev Info Button

The **Dev Info** button lists information for the highlighted device including certain notes and relevant precautions (Figure 2-8). The notes and precautions include algorithm settings, incorrect data pattern information, erasing procedures, etc.

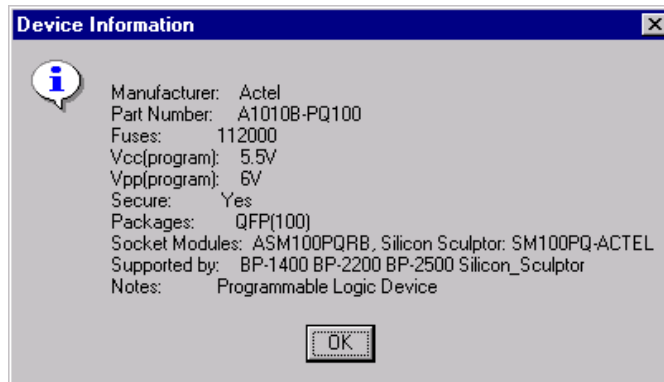

Figure 2-8. Device Information Dialog Box

Once you select a device and the Select Device window closes, the device information appears in the field next to the **Device** button. A note or warning may appear in the **Device Information** window to inform you of any additional relevant information.

Data Pattern Button

Once you make a device selection, you must choose a data pattern. Click the **Data Pattern** button to display the **Data Pattern** dialog box (Figure 2-9). Use this dialog box to load data into the buffer

from a file or another device. Browse to your file and load as necessary. The **Data Pattern** dialog box enables you to select a data pattern, clear the buffer, or edit the buffer.

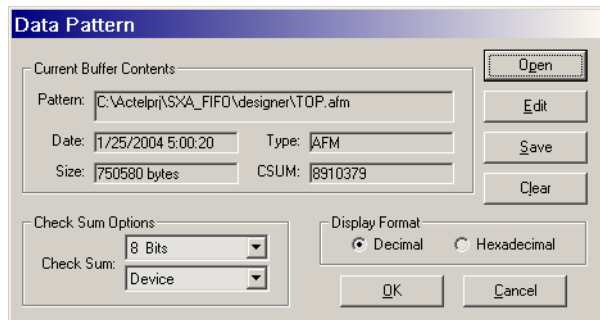

Figure 2-9. Data Pattern Dialog Box

Check Sum displays two fields with pull-down menus. You can select an 8- or 16-bit sum method. Device sums the number of bytes in the buffer equal to the byte count in the device you selected. If you load a file that is smaller than the device you selected, Silicon Sculptor uses the Default Buffer Value when summing the remaining bytes.

Open Button

The Open button brings up the Load File into Buffer window. Several options are available before loading the file. Actel's Antifuse devices use the AFM file formats, while Flash devices use STAPL or BIT file formats.

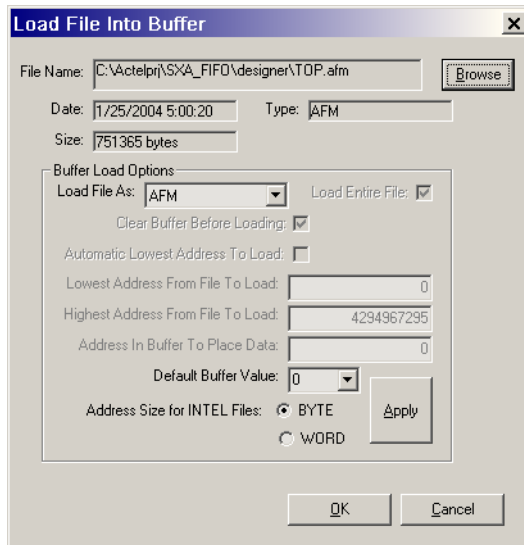

Figure 2-10. Load File Into Buffer Dialog Box

The **Load File As** pull-down menu allows you to specify the file type of the data you wish to load. Even though the software interrogates the file and automatically chooses the file type, it is important that you select the correct file type so that the correct data is loaded at the correct address. If the file type you select is not consistent with the type you wish to load, use the pull-down menu option to choose the appropriate type.

When you load the AFM file from the Load File Into Buffer dialog box, the programming software automatically disables the following options:

- Load entire file (checked as default)
- Clear buffer before loading (checked as default)
- Automatic lowest address to load
- Lowest address from file to load
- Highest address from file to load
- Address in buffer to place data

Decimal or Hexadecimal enables you to select a preference for viewing address information in any preceding fields.

Once you have determined your specs and are ready to load the file into the buffer, click **OK**. If you wish to exit without loading the buffer, click **Cancel**.

Summary: To load the buffer from a file, select the drive, directory, folder, and file. Select the file you wish to load, and then click the Open button. The Load File into Buffer window appears and prompts you to designate the file type. After you designate the data type for the file, the data is loaded into the buffer.

Save Button

The **Save** button brings up the **Save File from Buffer** dialog box and saves the buffer contents to disk. You can choose any local or network drive available when you save the file.

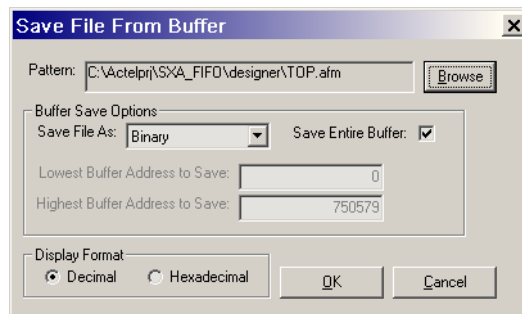

Figure 2-11. Save File from Buffer Dialog Box

- **File Name** text field is where you type the name of the data file. Actel recommends that you adhere to the standard 8/3 format (eight-character name followed by three-character extension for file type).
- **Save file as** field allows you to designate the file type when formatting the data file.
- **Save entire buffer contents** is checked by default. Uncheck this box if you wish to save a specific address range. When unchecked, the **Lowest** buffer address to save and the **Highest** buffer address to save options become available.
- **Lowest buffer address to save** field allows you to specify the lowest buffer address to save.
- **Highest buffer address to save** field allows you to specify the highest buffer address to save.
- **Decimal or Hexadecimal** enables you to select a preference for viewing address information in any preceding fields.

To save the file, click **OK**. To exit without saving, click **Cancel**.

Close Button

The **Close** button closes the **Data Pattern** dialog box without opening a file. If you save a file or make any checksum selections, these changes are saved over the original file and are active when you retrieve the file later.

Edit Button

Click the **Edit** button to edit the buffer contents.

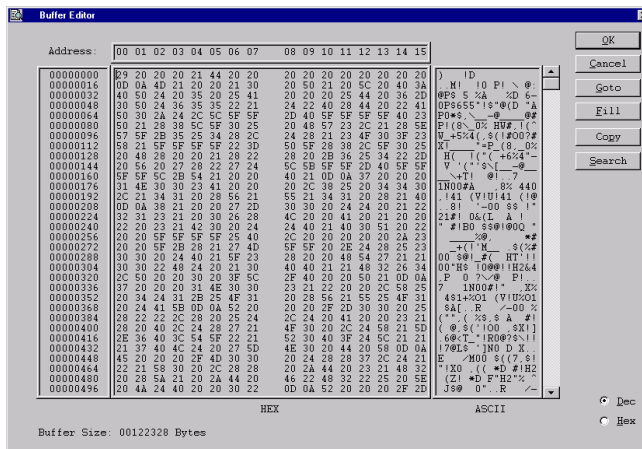

Figure 2-12. Buffer Editor Dialog Box

The **Buffer Editor** dialog box lists the addresses on the left of the screen, the data for each address in the middle with the fuse legend directly above, and the ASCII version of the file on the right.

The **Buffer Editor** window enables you to:

- **Goto** a certain memory location within the buffer
- **Fill** a range of addresses with a certain value
- **Copy** a specified memory range to another location within the buffer
- **Search** for a data pattern within the buffer
- Specify **Dec** or **Hex** via a button

The **Search** function enables you to start your search from a particular address (in the **Start Address** field) or search for a particular pattern of data (in the **Pattern** field). The **Pattern** field enables you to specify whether the pattern you are searching for is in hex or ASCII and whether the search goes forward or backward from the starting address.

Note: Actel recommends that you do not edit the programming file to avoid corruption.

Clear Button

The **Clear** button clears the buffer contents to the value specified as the default buffer value. This button only appears when the **Configure** menu option is set to **Experienced Mode**.

Options Button

The **Options** button enables you to set options specific to the data buffer. The default buffer value is 0x00. This option will fill the address locations not specified in the file to 0x00 or 0xFF, whichever is selected.

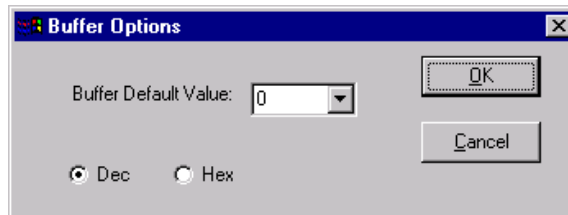

Figure 2-13. Buffer Options Dialog Box

Device Config Button

The **Device Config** button can only be found in **Demo** mode.

Job Master Mode

If you want to use the Job Master mode, notify BP Microsystems.

Main Screen File Tabs

Depending on the device you select, any of the following action/function file tabs can appear in your viewing screen.

Actel_ChkSum

Calculates, displays, and verifies the Actel design checksum for single-site operation. Verifies the design checksum of the program file to the checksum value programmed into the device. Also displays the 16-bit (4-hex) checksum and the 20-bit (5-hex) user-defined design ID.

Blank

Verifies that a device is blank (all fuses unprogrammed, or open). Prior to programming, verifies that a device has not been previously programmed. This operation is automatically executed prior to programming any device.

Program

Programs a device from data in the buffer. The **Program** button programs your design into the device. It also verifies that the correct device type is inserted into the socket and verifies the device is blank (unprogrammed) before programming begins.

Secure

Programs the Security fuse(s) to prevent unwanted probing of the device. You can program Security fuses on an Actel device that has had its Array fuses previously programmed. The ability to program Security fuses after programming Array fuses is designed to allow you to debug your device design with the Silicon Explorer diagnostic tool. After you debug your design, you can program the Security fuses to secure the device from further probing.

ACT 1 or 40MX Security Fuse Configurations

The ACT 1 or 40MX devices contain two security fuses: **Probe** and **Program**. Programming the Probe fuse disables the Probe Circuitry, which disables the use of the Debugger, ActionProbe, and Silicon Explorer diagnostic tools. Programming the Program fuse prevents further programming of the device, including programming the Probe fuse. [Table 2-2](#) summarizes the effects of programming the Security fuses on the PRA, PRB, SDI, and DCLK pins. In the normal operating mode (MODE=0), all undefined device pins in a design are automatically configured as active LOW outputs. Two exceptions are the SDI and DCLK pins. If the Program fuse is not programmed and SDI and DCLK are undefined, they are configured as inactive inputs. In this case, SDI and DCLK pins should be tied to ground. If the Program fuse is programmed and SDI and DCLK are undefined, they will become active LOW outputs.

Table 2-2. Security Fuse Configurations- ACT1 or 40 MX Devices

Mode ^a	Program	Probe	PRA, PRB	SDI, DCLK
Low	No (deselect)	No	User-defined I/O	User-defined Input Only ^b
Low	No	Yes ^c	User-defined I/O	User-defined Input Only ^b

Table 2-2. Security Fuse Configurations- ACT1 or 40 MX Devices (Continued)

Mode ^a	Program	Probe	PRA, PRB	SDI, DCLK
Low	Yes ^d	No	User-defined I/O	User-defined I/O
Low	Yes ^d	Yes ^c	User-defined I/O	User-defined I/O
High	No	No	Actionprobe Outputs ^e	Actionprobe Inputs ^f
High	No	Yes ^c	Actionprobe Disabled	Actionprobe Disabled
High	Yes ^d	No	Actionprobe Outputs ^e	Actionprobe Inputs ^f
High	Yes ^d	Yes ^c	Actionprobe Disabled	Actionprobe Disabled

a. The MODE pin switches the device between the normal operating mode (MODE=0) and the Probe Circuit mode (MODE=1).

b. The Program fuse must be programmed if the SDI or DCLK pins are to be used as an output or a bidirectional pin.

c. If the Probe fuse is programmed, the Probe Circuit is permanently disabled, which disables the Silicon Explorer diagnostic tool.

d. If the Program fuse is programmed, all programming of the device is disabled, including programming the array fuses and the Probe fuse.

e. The PRA output and a separate I/O buffer share the use of a single device pin. The PRA output and the output function of the I/O buffer are multiplexed. The same is true for PRB. The Probe Mode that is loaded into the Mode Register determines which output buffer is active during probing. There are three possible Probe Modes: “PRA only,” “PRB only,” and “PRA and PRB.”

When you select the “PRA only” mode, the PRA output becomes active and the output function of the I/O buffer associated with the PRA pin is inhibited. However, the input buffer portion of the I/O buffer associated with the PRA pin is still active. Any internal signal that appears on the PRA output is fed back through that input buffer to the internal Logic Modules. This could interfere with the expected function of the design during probing. Actel recommends that you use an input latch on PRA and PRB to prevent the feedback while probing. PRB functions as a normal I/O in the “PRA only” mode.

The “PRB only” mode is functionally equivalent to the “PRA only” mode. PRA also functions as a normal user I/O in the “PRB only” mode.

When you select the “PRA and PRB” mode, both the PRA and PRB outputs become active and the output function of the I/O buffers associated with both pins are inhibited. However, the input buffer of the I/O buffers associated with both pins are still active. Any internal signals that appear on the PRA and PRB outputs are fed back through the input buffers to the internal Logic Modules. This could interfere with the expected function of the design while probing. Actel recommends that you use an input latch on PRA and PRB to prevent the feedback during probing.

f. The SDI input and a separate I/O buffer share the use of a single device pin. The SDI input and the input function of the I/O buffer are connected in parallel. When the Mode pin is high, both inputs are active. The same is true for DCLK. External Probe Circuit control signals sent to those pins are also sent to the internal Logic Modules. This could interfere with the expected function of the design while probing. Actel recommends that you use an input latch on SDI and DCLK to prevent the external Probe Circuit control signals from effecting the functionality of your design during probing. If either SDI or DCLK are configured so that the output function of the I/O buffer is active, the Program fuse must be programmed. In this configuration, the signals from your design are fed back to the Shift Register and will interfere with the function of the Probe Circuitry. In addition, the I/O drivers will conflict the external SDI and DCLK drivers. Damage to both drivers could occur.

Non-ACT 1 or 40MX Security Fuse Configurations

All Actel devices other than ACT 1 or 40MX devices contain one Security fuse. Programming the Security fuse disables the Probe Circuitry, which disables the use of the ActionProbe and Silicon Explorer diagnostic tools. Table 2-3 summarizes the effect of programming the security fuse on the PRA, PRB, SDI, and DCLK pins.

In the normal operating mode (MODE=0), all undefined device pins in a design are automatically configured as active LOW outputs. You do not need to program the Security fuse to enable SDI and DCLK as active LOW outputs.

Table 2-3. Security Fuse Configurations- Non-ACT1 or 40MX Devices

Mode ^a	Security	PRA, PRB	SDI, DCLK
Low	–	User-defined I/O	User-defined I/O
High	No	Actionprobe Outputs ^b	Actionprobe Inputs ^c
High	Yes ^d	Actionprobe Inputs	Actionprobe Inputs

a. The MODE pin switches the device between the normal operating mode (MODE=0) and the Probe Circuit mode (MODE=1).

b. Please refer to Table 2-2 on page 40, item e.

c. The SDI input and a separate I/O buffer share the use of a single device pin. The SDI input and the input function of the I/O buffer are connected in parallel. When the Mode pin is high, both inputs are active. The same is true for DCLK. External Probe Circuit control signals sent to those pins are also sent to the internal Logic Modules. This could interfere with the expected function of the design while probing. Actel recommends that you use an input latch on SDI and DCLK to prevent the external Probe Circuit control signals from effecting the functionality of your design during probing. An input latch is an integral part of the I/O buffers in the non-ACT 1 devices. The output function of the I/O buffers associated with SDI and DCLK do not interfere with the function of the Probe Circuitry while in the Probe Mode. When the Mode pin is driven high, these outputs are inhibited. The I/O drivers do not interfere with the external drivers. However, these outputs are not observable in the Probe Mode.

d. If the Security fuse is programmed, the Probe Circuit is permanently disabled, which in turn disables the ActionProbe and the Silicon Explorer diagnostic tools.

Keyboard Usage and Hot-Keys

Actel Silicon Sculptor utilizes keystroke combinations, called **hot-keys** or **quick keys**, to allow you more freedom in invoking the program functions. Listed below are common keys and keystroke combinations used within the software. You can also use the keystroke combination **ALT + [underlined character]** wherever applicable.

For example, press **ALT+F** to open the File menu instead of using your mouse.

Table 2-4. Common Usage Keys

KEY	FUNCTION
Esc	Close the current window/retain original information. *Does not work in Configure window, must actually click on the Cancel button.
<-, ->	Move left or right to a selection.
Up arrow, down arrow	Move up or down to a selection.
Enter	Execute function command that is selected.

Table 2-5. Common Hot-Keys

KEY COMBINATION	FUNCTION
ALT-C	Opens Device Configure window (available only in Demo mode)
ALT-D	Opens Select Device window
ALT-E	Execute or Test, depending on device selected
ALT-F	Opens the File menu
ALT-H	Opens the Help menu
ALT-O	Used only in Data Pattern window; selects the Open button

Table 2-5. Common Hot-Keys (Continued)

KEY COMBINATION	FUNCTION
ALT-P	Selects the Program file tab
ALT-S	Selects Secure file tab or Stop button if Secure tab is not available.
ALT-T	Selects Tools drop down menu.
ALT-V	Selects Verify file tab.

Table 2-6. Dialog Box Command Functions

KEY	FUNCTION
Esc	Cancel the active window and return to Main Screen.
Enter	Exit the dialog box and execute command.
Home	Move to first selection of current line.
End	Move to last selection of current line.

Table 2-7. Edit Command Functions

KEY	FUNCTION
Up arrow, down arrow, left arrow, right arrow	Move cursor.
Home	Move to front of current line.
End	Move to end of current line.
CTRL-U	Upgrade window.
Enter	Make selection.

Troubleshooting

The information in this chapter can help you solve or identify a problem with your software and/or programmer. If you have a problem that you cannot solve, please contact Actel Technical Support. Actel is dedicated to making its software and programmers as trouble-free as possible.

Tech Support

You can get technical support from Actel whenever you experience a problem that you cannot solve. Refer to “[Product Support](#)” on [page 59](#) for contact information. Please have the following information ready when you contact technical support:

- The model number of the Actel programmer (title bar of secondary screen)
- The software version number (from the top of the main screen)
- The exact error message and error number received
- The exact algorithm that was selected
- The exact part number on the chip you were trying to program
- The command executed
- The results of running the self-test command on your programmer (BP Microsystems Diagnostics).

It is also useful to have a screen print of the error. You may be asked to send your programming file (PLEASE ZIP BEFORE SENDING) and/or send in your devices so we can analyze the error at the factory.

If you need to return your programmer to Actel for any reason, you must call and get a Return Material Authorization (RMA) number before shipping. Mark the RMA number clearly on the shipping container. Be sure to include a description of the problem experienced, a return address, contact person, and contact phone number.

Testing the Hardware

The programmer can test its hardware quite extensively. The self-test routine can detect problems in the pin-drivers, power supply, microprocessor, data cable, printer port, and several other circuits.

The hardware test cannot detect problems resulting from a dirty socket.

Note: Remove any chips from the programmer site(s) before you proceed.

The SculptWin software enables you to test all applicable parts within the device programmer for accuracy. This test helps to ensure that the programmer is running at performance standards.

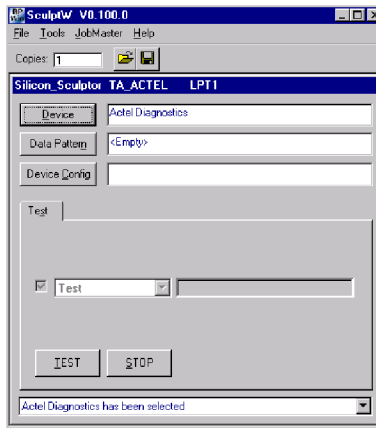

Figure 3-1. SculptWin Dialog Box with Test Information

To begin running the self-test on your device programmer, click the **Device** button and select **Actel Diagnostics** from the list of available devices, or type **diagnostics**. Once selected, the main window displays the Actel Diagnostics label in the **Device** field and a **Test** file tab appears (Figure 3-1). To begin testing the programmer, click the **Test** button. The **Test** dialog box opens, as shown in Figure 3-2.

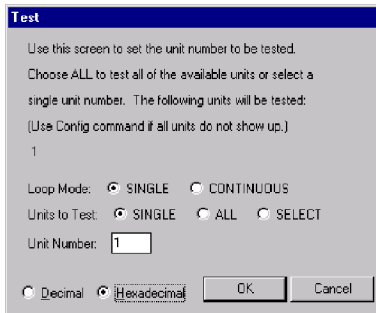

Figure 3-2. Test Dialog Box

The **Test** dialog box verifies how many units you want to test. After you click **OK** to begin the test, a window appears to prompt you to ensure that there is no chip in the socket (Figure 3-3).

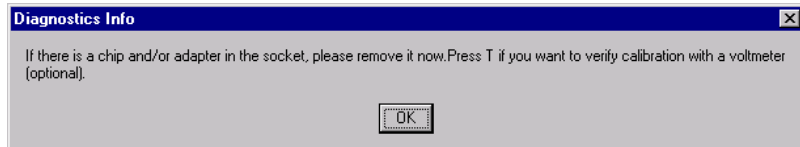

Figure 3-3. Diagnostics Info for Self Test Window

The test begins and runs until it is done or until you click on the **Stop** button. If you decide to cancel the self-test, click the **Stop** button at any time during the procedure. A window appears to acknowledge the operation was aborted (Figure 3-4). To re-execute the test, simply click the **Test** button again.



Figure 3-4. Self-Test Abort Window

Your programmer should pass the test. Verify by checking the green **PASS** LED on the chassis of the programmer. If your programmer does not pass the test, the red **FAIL** LED activates and an error message will appear on the screen:

```
Error 47: Self-test failed. This unit may need service. Please call
technical support.
```

If this should happen, double-check the fidelity of the cable connections and try again. Note the exact error message and call for technical assistance if the message persists (see “[Actel Technical Support](#)” on page 59 for contact information.).

Software Updates

The control software for your programmer is updated on a frequent basis (typically every two months) to add features and provide you with support for new chips. Software updates can be obtained from Actel (see “[Customer Service](#)” on page 59 for contact information, or visit the Actel website at www.actel.com). Depending on the type of programmer you have (engineer, production,

or automated), upgrades and renewals may need to be made by contacting the Actel sales department.

If you decline the software/hardware upgrade and your software support runs out, the following message will appear when you select a part:

Error Code 57: Device Not Enabled

Your programmer is designed to be highly flexible and programmable, allowing it to program a wide variety of chips. Consequently, when a problem does arise, it can usually be fixed with a software update.

Actel recommends that you obtain the latest software revision before calling the support line with a software problem. The solution for many of technical support calls is the latest version of the software.

FAQs

The questions below represent a list of the most commonly asked questions from callers. It does not represent a complete list. Please visit the Actel website for more information.

What is the proper way to handle the programming file for electronic transfer?

Actel strongly recommends that you always ZIP the programming files before performing any file transfers electronically. This will ensure that the integrity and contents of the programming file are intact and will avoid file corruption during transfer.

The Silicon Sculptor II does not communicate with computers installed with Windows 2000/WinXP, and the GUI is fixed in Demo Mode. What is the communication problem and why is the GUI fixed in the Demo Mode?

Silicon Sculptor IIs are based on the BP x600 technology. These programmers are faster than other programmers from BP partly because they use EPP, communication on the LPT1 port. The Silicon Sculptor I communicates using bi-directional, ECP, or EPP. You must set the Silicon Sculptor II to EPP; otherwise, it does not communicate on most computers and the GUI is fixed in Demo Mode.

You need to go into the BIOS setup, find the LPT1 port settings, and change the LPT1 Port Mode to EPP.

However, there may be cases where the Silicon Sculptor II will still fail to communicate with computers installed with Windows 2000 operating systems, no matter which parallel port setting is set.

In this case, if the Sculptor II still cannot communicate with the computer, the parallel port cable may be the cause of the problem. Silicon Sculptor IIs must use IEEE 1284 compliant parallel port cables. Please make sure the parallel port cable is IEEE 1284 compliant.

Why does the SculptW NT 4.0 software keep failing?

The device drivers are not installed or are not being recognized by the software. The Actel software that runs on an NT environment is attempting to establish communication with the device programmer through the drivers. When the drivers are not found, it fails the software. To remedy this, install or re-install the device drivers for the software. Refer to the steps following the next question to obtain the device drivers and verify that the software is recognizing them.

Why isn't SculptW running in the NT environment?

The Windows NT 4.0 system requires the installation of a system device driver. The first step to is to find out whether a device driver is installed.

1. **Open the control panel.** Go to **Start > Settings > Control Panel**.
2. **Open Devices.** Double-click the **Devices** icon.
3. **Select the device BPNTDriver.** Verify that the device driver status is set to **started** and startup is set to **automatic**. If these selections are not designated for the device driver, click to select the driver. To set the status to **start**, click the **Start** button. NT attempts to start the device driver when you click the **Start** button. To set the driver startup to **automatic**, click the **Startup** button and select **Automatic**.

If for some reason the device driver does not install or you need to uninstall the driver, go to the command prompt. Go to the *NTDrv* directory in the default installation directory. For example, the default installation directory for Silicon Sculptor is *C:\siliconwin*.

- To uninstall from this directory type:

```
drvinst1 -u
```

- To install from this directory type:

```
drvinst1 -i
```

There are registry settings for the device driver and as soon as there is a full definition they will be added here.

In the DOS version, the configuration settings were saved to a file. Where did they go?

With the introduction of the Actel windows software, the configuration settings are no longer saved to a file. These settings are now being saved in the Windows 95/98/NT 4.0 registry and are not

deleted when they are uninstalled. This allows you to continue to use previous settings when upgrading to a new version of the software. There may be cases however, when you are required to delete these settings. To do so, execute the following steps:

1. **Run *regedit*.** Go to **Start > Run** and type **regedit**.
2. **Select ActelWin.** Select **ActelWin** from the **VB and VBA Program Settings** file list.
3. **Delete the ActelWin registry settings.** The ActelWin registry settings have now been deleted. The new registry settings appear in this directory upon re-installation or upgrade of the software.

Errors While Programming

If you experience problems while trying to program a chip, try to narrow down the problem. If you receive a **Cannot program** or **Cannot erase** error messages while programming:

- Make sure you have selected the proper device (i.e. the device programming algorithm).
- The device may have been previously secured; use **Blank Check** to verify whether or not the device is blank. (See the topic “Blank” on page 40 for more information.)
- The device may have a newer die than the one supported by the device (i.e. the device programming algorithm).

Cleaning a Dirty DIP Socket

If the DIP socket becomes dirty, it sometimes fails to make contact with all the chip pins. The simple fix is to place your chip in the socket, push the lever down, and slide the chip left and right a few times. Actel also recommends cleaning sockets with a blast of high-pressure air on a regular basis.

If this does not resolve the problem, run the hardware self-test described above. If your hardware passes the self-test, there may be an error in the programming algorithm you are using or Actel may have updated the programming algorithm for your device. In either event, you can probably correct your problem with a software update.

Error Messages and Suggested Actions

Error messages are usually generated by the device programmer. When you receive an error message, refer to the appropriate device programmer manual's troubleshooting section. The following is a list of error messages that could originate from the software.

Version Mismatch - BPEng.dll and BPAIg.db versions mismatched

The engine and algorithm database versions do not match. Accepting this error message prompts an exit from the software. Contact technical support for further assistance. Refer to “[Actel Technical Support](#)” on page 59 for contact information.

BPPgmr.ocx - BPPgmr.ocx internal error

SculptW generates this error when the unique coding sequence attached to both the BPPgmr.ocx and the BPEng.dll do not match. Accepting this error message prompts an exit from the software. Contact technical support for further assistance. Refer to “[Actel Technical Support](#)” on page 59 for contact information.

Algo Database Error - Error loading BPAIg.db

This is a “catch all” error code. SculptW generates this error if anything not listed above causes an error while loading the algorithm database. Accepting this error message prompts an exit from the software. Contact technical support for further assistance. Refer to “[Actel Technical Support](#)” on page 59 for contact information.

BNPtlodll - No parallel port is available

ActelWin NT 4.0 generates an error if the device drivers are not installed. The software attempts to establish communication with the programmer through the driver. When the driver is not found, it fails the software. In order to remedy this, you must install the device drivers for the software. Please refer to “[FAQs](#)” on page 50 for procedures.

Error 3: Cannot reset hardware

The software cannot establish communication with the programmer:

- Be sure the programmer has power and that the green PASS LED is on. Since the programmer performs an automatic Power On Self Test (POST) on startup, it could be that the programmer failed the test and has signaled the software into the default DEMO mode. If this should happen, contact technical support for further assistance. See “[Actel Technical Support](#)” on page 59 for contact information.
- Make sure the cable from the programmer to the computer is properly connected to a parallel printer port. If you are using a ribbon cable, this is probably the problem (ribbon cable connectors are designed for use inside a chassis where the cable is not flexed). You should use a shielded 25-pin standard IEEE 1284 compliant cable, not an RS-232 cable.
- Check your LPT port. If you have multiple parallel ports, you may have the ports configured incorrectly, with two at the same address.
- Some laptops have the ability to disable the port. If you are working on a laptop, make sure the LPT port is enabled.

- Another program (such as a print cache) may be interfering with the port. When running under Windows, you increase the likelihood of another program trying to access the same parallel port and changing the expected status at the port.
- If you have a hardware lock key between the programmer and the port, try removing it.
- The programmer may be damaged. Try using a different computer and/or parallel port and see if it works.

Error 5: Hardware time-out

The software issues this error message when it is waiting on a response from the programmer while executing a command and the programmer does not respond within the expected amount of time. This error can result from several causes. You may be experiencing communication errors (see “[Error 3: Cannot reset hardware](#)” on page 53). There may be a bug in the software for this particular algorithm (see “[Error 10: Error in programming algorithm. Please call technical support.](#)” on page 54). Refer to “[Testing the Hardware](#)” on page 47 for more information.

Error 6: Wrong model number

See “[Error 3: Cannot reset hardware](#)” on page 53 for possible causes.

Error 8: LPTx: is not a functioning port

The parallel port LPTx (where x=1, 2 or 3) that is selected with the Configure command does not exist on your computer, is not functional, or has a bad cable connected to it.

Error 9: Programmer execution error

The programmer failed an internal consistency check. See “[Error 3: Cannot reset hardware](#)” on page 53 and “[Error 5: Hardware time-out](#)” for possible causes.

Error 10: Error in programming algorithm. Please call technical support.

The software has detected an internal error. You should contact Actel to report the error. You may need to upgrade your system with the most recent release of the software posted on the Actel website. See “[Actel Technical Support](#)” on page 59 for contact information.

Error 11: There is no data in the buffer. You must load a file or read a chip.

A command tried to read data from the buffer to program or verify a chip, but nothing has been loaded into the buffer yet or the buffer was recently cleared.

Error 14: There is no chip in the programmer site

Be certain that you inserted your chip correctly. If it was inserted correctly, remove it and run the hardware self-test to be sure your programmer is functioning correctly using Actel Diagnostics (see “Testing the Hardware” on page 47).

A defective chip may also cause this error. When using an autohandler, the contactor may not have closed or the connection between the programmer and the contactor may be disconnected.

Error 15: The chip is not inserted in the programmer site correctly

The continuity test determined that the chip in the programmer site does not have continuity on all the proper pins. You should examine these pins carefully. Possible causes are:

- A bent pin
- The chip is not in the proper position in the programmer site.
- The chip has a different number of pins than the chip selected.
- The algorithm selected has a *, indicating that it requires an adapter but you did not use the adapter, or vice-versa.
- The socket is dirty and not making a connection. See “Cleaning a Dirty DIP Socket” on page 52 for more information.
- The wrong socket module or adapter is being used for this part.
- The device may be a very low power device that is not properly detected by Actel’s continuity methodology. If so, please let us know.

Note: It’s not easy to get continuity on an LCC device in a PLCC socket. If you are trying to do so, you may need to add a spacer between the chip and the lid in order to apply the proper force to the device pins. The best solution is to purchase an LCC socket module that does not require any such modification. Also, LCC devices do not work at all in the autoject sockets designed strictly for PLCC devices.

Error 16: The chip is inserted backwards

The chip has passed the continuity tests, but appears to have the GND and V_{cc} pins improperly placed in the socket. If LCC, PLCC, or QFP is not accidentally rotated, then the device is probably defective. Try a known good device.

Error 17: Out of base memory. You should have at least 200K free.

Your computer’s configuration does not have enough RAM available to run the software. You should have 640K RAM installed with at least 200K available for program execution. Memory resident programs, such as network drivers, can reduce the RAM available to the programmer, so you may need to remove these programs from your CONFIG.SYS and AUTOEXEC.BAT files.

Error 18: Temporary file error

The software's virtual memory manager is trying to store data that is currently not needed in RAM to the disk. The program was unable to create a temporary file, or the disk is full. Make sure you have plenty of disk space (the larger the data files, the larger the requirement for temporary disk space). The program does take advantage of EMS memory if you have an expanded memory manager installed. This is much faster than using the disk for temporary swap space.

Error 21: Cannot program

Not able to program the device in the programmer site. See “Errors While Programming” on page 52 for more information.

Error 23: Invalid electronic signature in chip (device ID)

- The chip may be damaged or the programming algorithm may have changed.
- The orientation of the device may be misorientated. Make sure the device is inserted properly.

Error 24: Invalid electronic signature in chip (algorithm ID)

The chip may be damaged or the programming algorithm may have changed.

Error 26: Device is not blank

The Device/Blank command was executed or the **Blank check before programming** option was enabled in the Device/Options dialog box, and the device in the programmer site is determined to have programmed data. You may have used the wrong algorithm, or the device may have been programmed previously.

Error 27: Device is not secured

An attempt to secure a device was made, but it failed. See “Errors While Programming” on page 52 for more information.

Error 31: Database file is invalid. The .EXE file is corrupted.

The .EXE file you are executing has been corrupted. You should uninstall and then reinstall the software to fix the executable. See “Actel Technical Support” on page 59 for contact information.

Error 32: Sorry, algorithm not found. Please call technical support.

The .EXE file you are executing has been corrupted. You should get a new copy from Actel. See “Actel Technical Support” on page 59 for contact information.

Error 33: You must reselect the chip you want to program.

The device was selected before establishing communication with the programmer; this may have been done prior to turning on the programmer or before switching to a different programmer. Reselect the chip and the error should not re-occur.

Error 36: You must properly install the correct socket module.

You will get this error message if:

- No socket module is installed.
- The socket module installed does not support the device you have selected.
- The socket module installed is not supported by the version of the software you are using. Use the latest version.
- The pinout has not yet been defined for this package type. Verify that the other possible causes have been eliminated. If so, this may be an oversight on Actel's part. In a case of persistent error, please contact technical support with the data. See [“Actel Technical Support” on page 59](#) for contact information.

Error 39: Device already secured

The device cannot be legitimately programmed, read, etc., because it is secured. If it is a PLD, it may still be functionally tested with the Test command under the Test tab (see [“Testing the Hardware” on page 47](#)).

Error 44: Internal error. Please call technical support.

The software detected an internal inconsistency. This may be caused by the computer not performing correctly. Contact technical support. See [“Actel Technical Support” on page 59](#) for contact information.

Error 46: AFS software required to execute this function

This is a function that is available to users who have purchased the Advanced Feature Software only. In order to use the chosen function you must purchase the AFS upgrade.

Error 47: Self-test failed. This unit may need service. Please call technical support.

The self-test (Actel Diagnostics) has detected a hardware problem. The unit may need to be returned for repair. Note the exact error message and contact Technical Support. See [“Actel Technical Support” on page 59](#) for contact information.

Error 57: You must purchase support for this device to use it.

The device that you selected is not supported in the default device set for this programmer. Call Actel Sales to purchase an upgrade code for your programmer (see [“Product Support”](#) on page 59 for contact information).

Error 70: The buffer data cannot be used to program this device.

You loaded a file type that is not a valid option for the currently selected device. Re-select the device and load the buffer again. If the error persists, call technical support. See [“Actel Technical Support”](#) on page 59 for technical support contact information.

Product Support

Actel backs its products with various support services including Customer Service, a Customer Technical Support Center, a web site, an FTP site, electronic mail, and worldwide sales offices. This appendix contains information about contacting Actel and using these support services.

Customer Service

Contact Customer Service for non-technical product support, such as product pricing, product upgrades, update information, order status, and authorization.

From Northeast and North Central U.S.A., call **650.318.4480**

From Southeast and Southwest U.S.A., call **650.318.4480**

From South Central U.S.A., call **650.318.4434**

From Northwest U.S.A., call **650.318.4434**

From Canada, call **650.318.4480**

From Europe, call **650.318.4252** or **+44 (0)1276.401500**

From Japan, call **650.318.4743**

From the rest of the world, call **650.318.4743**

Fax, from anywhere in the world **650.318.8044**

Actel Customer Technical Support Center

Actel staffs its Customer Technical Support Center with highly skilled engineers who can help answer your hardware, software, and design questions. The Customer Technical Support Center spends a great deal of time creating application notes and answers to FAQs. So, before you contact us, please visit our online resources. It is very likely we have already answered your questions.

Actel Technical Support

Visit the [Actel Customer Support website \(www.actel.com/custsup/search.html\)](http://www.actel.com/custsup/search.html) for more information and support. Many answers available on the searchable web resource include diagrams, illustrations, and links to other resources on the Actel web site.

Website

You can browse a variety of technical and non-technical information on Actel's [home page](http://www.actel.com), at www.actel.com.

Contacting the Customer Technical Support Center

Highly skilled engineers staff the Technical Support Center from 7:00 A.M. to 6:00 P.M., Pacific Time, Monday through Friday. Several ways of contacting the center follow:

Email

You can communicate your technical questions to our email address and receive answers back by email, fax, or phone. Also, if you have design problems, you can email your design files to receive assistance. We constantly monitor the email account throughout the day. When sending your request to us, please be sure to include a detailed description of the problem you are experiencing, your full name, company name, and your contact information for efficient processing of your request.

The technical support email address is tech@actel.com.

Phone

Our Technical Support Center answers all calls. The center retrieves information, such as your name, company name, phone number and your question, and then issues a case number. The Center then forwards the information to a queue where the first available application engineer receives the data and returns your call. The phone hours are from 7:00 A.M. to 6:00 P.M., Pacific Time, Monday through Friday. The Technical Support numbers are:

650.318.4460

800.262.1060

Customers needing assistance outside the US time zones can either contact technical support via email (tech@actel.com) or contact a local sales office. [Sales office listings](#) can be found at www.actel.com/contact/offices/index.html.

Glossary

BGA	Ball Grid Array. A surface mount device with solder balls and a high pin count, similar to PGA.
blank check	A test performed by a device programmer to ascertain whether a device has been programmed (partial or total) or is in a virgin state.
checksum	A number that results by adding up every element of a pattern. Typically either a four or eight digit hex number, it is a quick way to identify a pattern, since it is very unlikely that two patterns will have the same checksum.
compare	Reading a programmable device and displaying any discrepancies from the desired pattern. Each error is displayed on the screen. This comparison is slower to perform than a verify on the programmer.
concurrent programmer	A multiple-socket programmer that starts programming each device as soon as it is inserted in a socket, without all sockets having to be filled.
device	Microchip or Integrated Circuit chip.
dialog box	The method used by the device programmer's user-interface software to allow the user to select options and specify information. The user can specify any options and fill any blanks in the box then press ENTER to force the software to process the information.
die	The silicon chip that is located within an IC package. It is a small rectangular flat piece of silicon that has been fabricated with many transistors to perform a specific function. It is glued into a plastic or ceramic package and connected to the external metal interconnect pins of the IC with very small bonding wires.
FPGA	Field Programmable Gate Array. A very complex PLD. The FPGA usually has an architecture that comprises a large number of simple logic blocks, a number of input/output pads, and a method to make random connections between the elements.
gang programmer	A multiple-socket programmer that requires each device to be placed in a socket before any can be programmed. See <i>Concurrent Programmer</i> .

ground bounce	A phenomenon that limits the testability of high-speed PLDs on some device programmers. The term refers to the voltage on the ground terminal of the PLD's die rising and falling when many outputs switch simultaneously. This voltage can induce extraneous clock signals that will make a device fail a functional test or reduce programming yield.
hex file	A human-readable ASCII file that represents any binary data. Each byte in the binary pattern is represented by two hex characters (0-9, A-F) so that any of the 256 possible bytes, which include both control and unprintable characters, may be printed. The hex file may also contain address or checksum information. The pattern represented by the hex file may be represented by a binary file or any of the hex file formats – any file format may contain any pattern.
I/O	Input / Output.
JEDEC	Joint Electron Device Engineering Council (pronounced JED'eck). A group organized by the IEEE (Institute of Electrical and Electronics Engineers) that has defined a standard file format for PLDs.
JEDEC file	A file conforming to a standard format that specifies the configuration and testing procedure for a PLD. The file is in a human-readable ASCII format and consists of fields that start with a letter and end with an asterisk. Fields specify the pattern to program into the part, whether to secure the device, a set of test vectors to perform a functional test, and checksums to verify the integrity of the file.
LCC	Leadless Chip Carrier. A square ceramic package that has no leads; instead it has metal areas that are surface-mount soldered to the target circuit. This package is usually used only for military and aerospace applications. Available up to 84 pins.
oscillator	A device that produces an alternating output current.

OTP	One-time programmable. The characteristic of a memory device that can be programmed once but cannot be erased. When an EPROM is described as OTP, this means that its die is erasable when exposed to ultraviolet light, but because of its package, which is not transparent, it cannot be exposed to light and thus it cannot be erased.
package	The plastic or ceramic that protects an IC die and connects it to the target circuit.
parallel printer port	A standard port on virtually every PC designed for connection to a printer. This port has eight data lines and several control lines. Parallel ports may be either unidirectional or bi-directional. If your computer has a unidirectional port, the programmer will use the status lines to read data back from the programmer. The port allows high-speed communication (many times faster than a serial port). There may be up to three parallel ports in most PCs designated LPT1, LPT2, and LPT3.
PGA	Pin Grid Array. A square, through-hole IC package that has pins located on a square grid with 0.1000-inch pitch. It may have up to several hundred pins. Used primarily for military and prototype designs.
PLCC	Plastic Leaded Chip Carrier. A square plastic package that has J-shaped leads on four sides. This can be surface mounted or placed in a socket for through-hole use. Available in 20 to 84 pins.
PLD compiler	A software package that allows an engineer to specify the functionality of a PLD through a high-level language or schematic diagram. The software will convert the design into a JEDEC or other file for the PLD programmer. PLD compilers are available from numerous IC manufacturers and from third parties. The packages from IC manufacturers support only one brand of device and may be free, inexpensive or expensive.
pneumatic	Of or pertaining to air, gases or wind.
PQFP	Plastic Quad Flat Pack. See <i>QFP</i> .
QFP	Quad Flat Pack. A square IC package that has surface-mount leads coming from four sides. It is used for high-density applications, usually over 100 pins. Lead pitch may be 0.025 inches or smaller.

socket module

An interchangeable metal chassis that contains a programming socket.

TQFP

Thin Quad Flat Pack. Similar to QFP but with a lower profile and physically smaller in length and width.

For more information about Actel's products, visit our website at <http://www.actel.com>

Actel Corporation • 2061 Stierlin Court • Mountain View, CA 94043 USA
Customer Service: 650.318.1010 • Customer Applications Center: 800.262.1060

Actel Europe Ltd. • Dunlop House, Riverside Way • Camberley, Surrey GU15 3YL • United Kingdom
Phone +44 (0)1276.401452 • Fax +44 (0)1276.401490

Actel Japan • EXOS Ebisu Bldg. 4F • 1-24-14 Ebisu Shibuya-ku • Tokyo 150 • Japan
Phone +81.03.3445.7671 Fax +81.03.3445.7668

Actel Hong Kong • 39th Floor, One Pacific Place • 88 Queensway, Admiralty Hong Kong
Phone +852.227.35712 Fax +852.227.35999

5029111-1/03.04

